

No. 609,050.

Patented Aug. 16, 1898.

I. RUDENSKY.
DEVICE FOR TRANSMITTING POWER.

(Application filed Feb. 8, 1898.)

(No Model.)

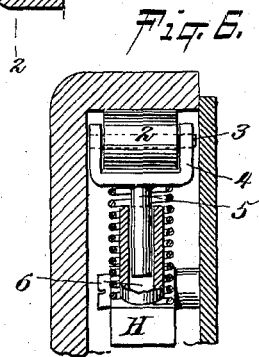
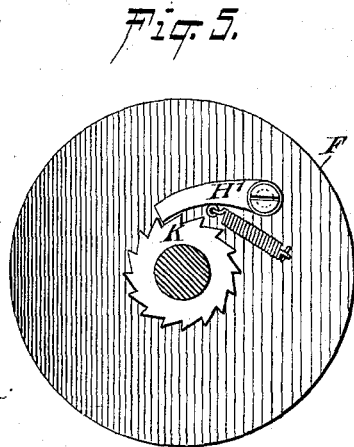
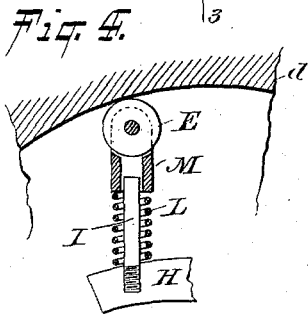
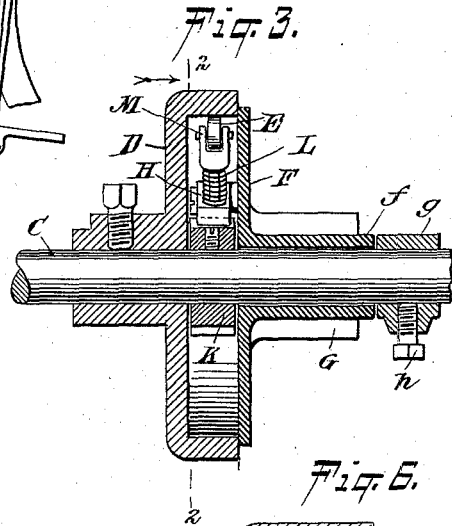
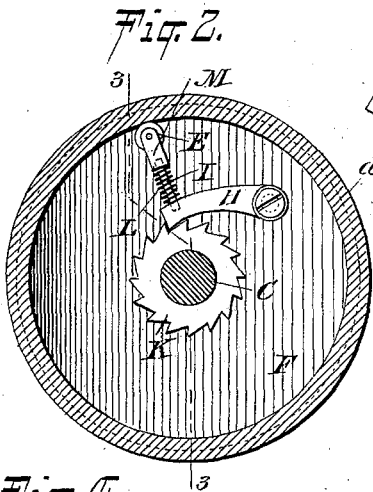
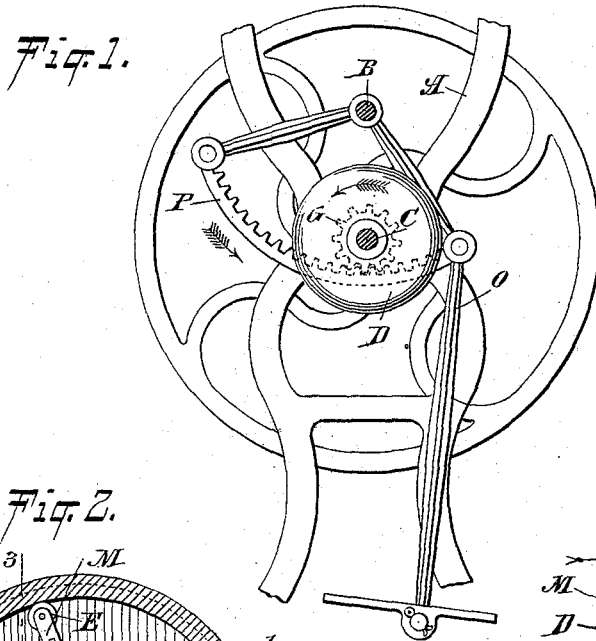

WITNESSES:
William P. Goebel.
M. Van Natwick.

INVENTOR
Israel Rudensky
BY
George L. ...
ATTORNEY.

UNITED STATES PATENT OFFICE.

ISRAEL RUDENSKY, OF NEW YORK, N. Y.

DEVICE FOR TRANSMITTING POWER.

SPECIFICATION forming part of Letters Patent No. 609,050, dated August 16, 1898.

Application filed February 8, 1898. Serial No. 669,492. (No model.)

To all whom it may concern:

Be it known that I, ISRAEL RUDENSKY, a subject of the Czar of Russia, and a resident of New York, in the county of New York and State of New York; have made and invented certain new and useful Improvements in Devices for Transmitting Power, of which the following is a specification.

My invention relates to an improvement in devices for applying or transmitting power, and more particularly to devices of this kind or character adapted for use in connection with sewing-machines, lathes, and other apparatus wherein the parts are operated by foot-levers, the object and purpose of my invention being to construct and arrange means which shall be certain in operation and which may be substituted for the several kinds or styles of friction-clutches usually employed for the same purpose.

It is well known to those skilled in the art that unless a friction-clutch, and especially such as is made entirely from metal, be nicely constructed and the parts perfectly fitted it is uncertain in its operations, and also that in course of time the two metal surfaces coming in frictional contact are worn smooth, the effect being to render the clutch useless and practically worthless.

The object of my invention is to overcome these difficulties and provide means which shall at all times be certain in their operations, cheap to manufacture, and not easily broken or destroyed.

With these and other ends in view my invention consists in certain novel features of construction and combinations of parts, as will be hereinafter fully described, and pointed out in the claims.

In the accompanying drawings, Figure 1 represents a portion of a frame of a sewing-machine, foot-lathe, or other similar device having my improved mechanism attached thereto. Fig. 2 is a face view, partly in section, taken on the line 2 2 of Fig. 3. Fig. 3 is a sectional view taken on the line 3 3 of Fig. 2. Fig. 4 is a detail view showing the arrangement of the several parts of the pawl. Figs. 5 and 6 are views of modifications.

Referring to the drawings, A represents a

portion of the framework of a sewing-machine, lathe, or other similar device, and more particularly one of the standards or brackets for supporting the operating mechanism, a rod or shaft B extending from the leg or standard A to a similar standard at the opposite end of the machine, (not shown,) and a shaft C also extending from one standard to the other and mounted in bearings secured in or to said standards.

To the shaft C is bolted or otherwise secured the circular plate or disk D, provided with the flange *d*, the inner surface of the latter forming a track or bearing-surface for the roller E, forming a part of the pawl, as will be hereinafter described. On the driving-shaft C is loosely mounted a disk or circular plate F, provided with the hub *f*, on which is formed a gear G; said plate or disk being held in position against the outer edge of the flange *d* by means of a ring or collar *g*, fitting around the shaft C and held in place by the set-screw or bolt *h*, said disks or plates D F forming, when the parts are arranged as shown in Fig. 3, a box or casing.

To the disk F is pivoted a pawl consisting of the arm H and the arm I, the latter extending at right angles to said arm H, the end of the pawl engaging with the ratchet K, keyed or otherwise secured to the driving-shaft C within said box or casing. Around the arm I of said pawl is wound a spring L, the lower end bearing against the arm H, and on the upper end of which rests the sleeve M, fitting around the upper end of said arm I, and on which is mounted a roller E, the latter bearing against and traveling on the inner surface of the flange *d* of the disk or plate D, the tendency of said sleeve and roller being to retain the pawl in engagement with the ratchet K.

On the shaft B is fulcrumed the driving-lever O, constructed as shown in Fig. 1 and having the curved rack-bar P secured thereto or formed thereon, the teeth of which engage with the gear G.

It will be understood that my device is used in pairs located at the opposite ends of the machine and so connected with each other by means of strings or straps (not shown) that while the lever O is pushed or forced in one

direction the other lever will travel in the opposite direction. As the manner and means for operating devices in this way are well understood by all mechanics, no details of description are necessary.

5 In practice when the lever O is forced forwardly the rack-bar P, engaging with the gear G, will operate to revolve the shaft C by reason of the fact that the pawl is held in engage-
 10 ment with the ratchet K. On the return stroke of the lever O the roller E travels around the inner surface of the flange *d*, the pawl being allowed to ride over the ratchet-
 15 teeth by reason of the compression of the coiled spring L. Instead of forming the pawl as shown in Fig. 5, wherein the arm H is secured to the disk F and engages with the ratchet K,
 20 H' and at its opposite end to said disk, this device performing the same work and accomplishing the same purpose as the one above described. Further, instead of constructing
 25 the pawl as shown in Figs. 2, 3, and 4 it might be constructed as shown in Fig. 6, wherein the roller is mounted on the spindle 3, the
 30 ends of which rest in the yoke 4, the arm or post 5 of which is extended into the hollow arm or sleeve 6, said arm 6 being formed integral with or secured to the arm H of the pawl.
 35 A spring 7 is coiled around the arm 6 and bears against the yoke 4 at one end and at its opposite end against the arm H, the effect being to hold the pawl in engagement with the ratchet K during the travel of the roller

2 on the inner surface of the flange *d*, as in the instance before described.

Having fully described my invention, what I claim as new, and desire to secure by Letters Patent, is—

1. In a power-transmitting device, the combination with a shaft, of a disk or plate secured thereto and provided on its edge with a flange *d*, a second plate or disk loosely mounted on said shaft and having a pinion formed thereon, a ratchet secured to the shaft between said plates, a spring-actuated pawl pivoted to said second plate and engaging with the said ratchet, and bearing against the inner surface of said flange, and a rack-bar as described.

2. In a power-transmitting device, the combination with a shaft, of a plate D secured thereto, and provided with a flange *d*, a disk F mounted on said shaft and provided with a pinion, a ratchet secured to said shaft between said plates, a spring-actuated pawl pivoted to said plate F and provided with a roller traveling on the inner surface of said flange and holding said pawl in engagement with the ratchet, and a rack-bar for engaging with said pinion, substantially as described.

Signed at New York, in the county of New York and State of New York, this 3d day of February, A. D. 1898.

ISRAEL RUDENSKY.

Witnesses:

JOHN F. FLAGG,
 M. VAN NORTWICK.